



Product line

HUMANITARIAN ACCOMMODATION TENTS

Temporary structures for
fast and flexible operations



HTS
TENTIQ



Contents

- 4 Humanitarian accommodation tents
- 6 Emergency Tents UKMZ-H
- 8 Inflatable Tents ABZ-H
- 10 Troop Tents TRZ-H
- 12 Large Tents GZ-H
- 14 Accessories overview

Who we are

HTS TENTIQ creates spaces for great things – because we believe an ideal space solution exists for every sector and every application. For many years we have been making an impact in the tent industry as experts in development, manufacturing, quality, selection, technology, customer service and innovation made in Germany. We produce temporary and innovative space solutions for your future – and within the shortest possible time.

Our wide range of products leaves nothing to be desired. We implement custom designs and sector-specific solutions quickly and easily thanks to our comprehensive technical expertise. On the basis of continuous product development and a focus on flexibility, quality, sustainability and reliability, we are able to offer our customers the best products in the sector along with premium service worldwide. However, HTS TENTIQ not only creates space, but also adds value. To this end, we always keep the big picture in mind. Our environment is just as important to us as our employees and fellow human beings. Benefit from our years of experience and let us advise you. Our highly qualified staff always knows exactly which tent system suits you best.

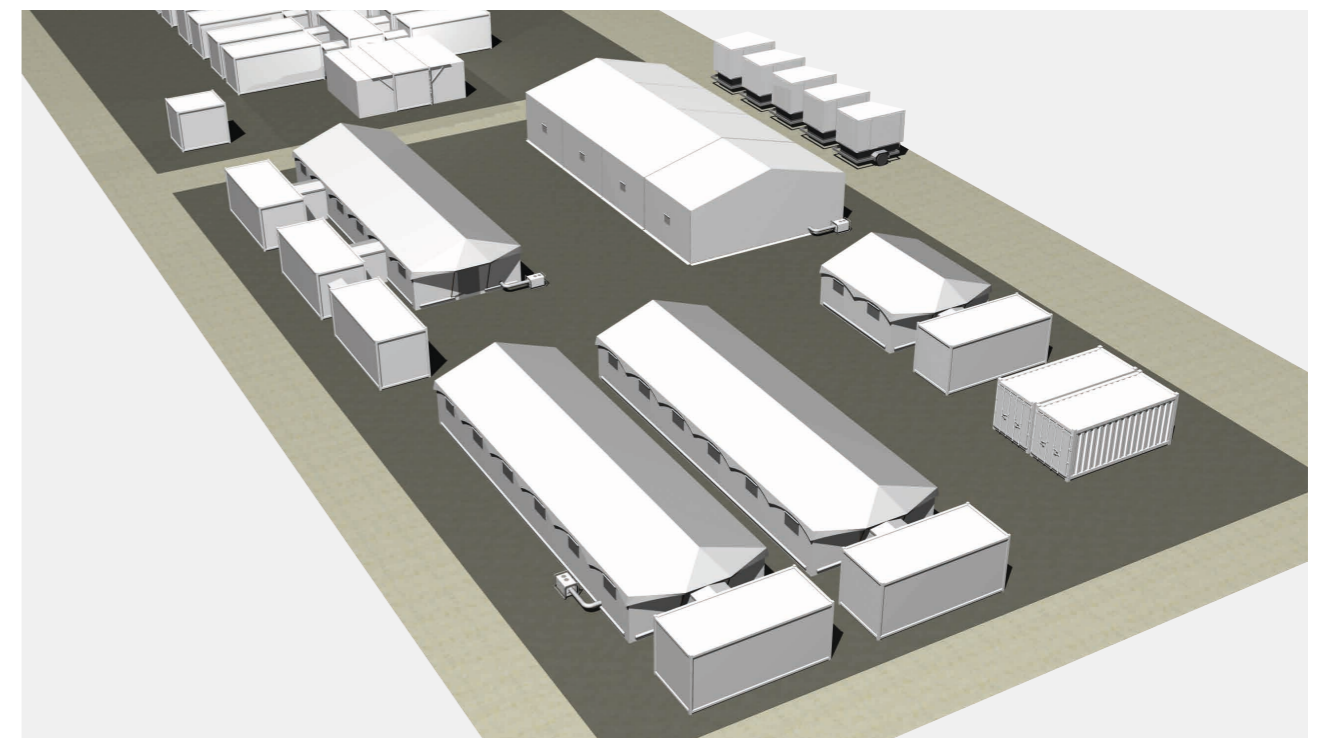

Humanitarian accommodation tents

Strong, reliable tents for accommodation and work areas for all humanitarian operations. We offer a large range of innovative and inexpensive emergency tents for the civil protection and humanitarian organisations. All of our tent systems are designed for rapid deployment and maximum performance in the most extreme environmental conditions and climates. Each tent model is available in various standard sizes and customized configuration.



Emergency Tents UKMZ-H

Quick and lightweight shelters to accommodate small or large groups for humanitarian use. Short-term usage and quick set up without tools.

- Set up takes 3 people around 15 minutes depending on the size and configuration
- Adjustable to different weather conditions and challenges
- Many variations and equipment options



Inflatable Tents ABZ-H

Innovative tent systems for global humanitarian use, providing the ideal environment for fast accommodation and medical care.

- Fast assembly in around 5 minutes with electrical air pump
- Low transport volume and total weight
- Wide range of applications with an extensive range of accessories like windows, doors, HVAC* ducts, partitions, connecting corridors

* Heating, ventilation & air conditioning



Troop Tents TRZ-H

Set up and dismantled quickly. They can be adapted to your individual requirements and are suitable for long-term usage in all weather conditions. There is also a wide range of accessories and configuration options.

- Set up by 4 people within approximately 20 minutes depending on the size and configuration
- Multi-functional
- Optionally equipped with soft insulating covers, different kinds of flooring systems, partition walls to create small private rooms, additional accessories such as doors, windows and more.



Large Tents GZ-H

With big internal space, large tents are ideal for canteens, accommodation rooms, waiting and rest areas for humanitarian purposes. Long-term usage with a huge range of optional accessories and configuration.

- Adapted to suit a wide range of weather conditions including high wind and snow for all areas worldwide
- Optionally equipped with soft and hard walling and roofing system. Soft and hard insulation, different kinds of flooring systems, doors, windows and more.



Emergency Tent UKMZ-H

You can always rely on our tent designs. To provide you with the right accommodation for your team's activities in the field, we have developed our accommodation and team tents. The plug-in system guarantees quick and easy set up and dismantling with little effort or prior knowledge. Our shelters are available in various sizes and can be adapted to suit your requirements with a range of accessories such as floor coverings, partition walls or connecting walkways. There is sufficient space for

everyone in our emergency tents, whether you need a tent for a small group of 4 - 6 people, or for 20 people. Nine different sizes are available, with lengths ranging from 4.00 to 12.00 meters. The maximum size of an emergency tent is around 70 m². Numerous fire brigade and church associations, municipalities and aid organizations successfully use the accommodation and team tents for operations, festivals and camps or as fire brigade tents.

Specifications

- Quick assembly and disassembly
- Simple and easy plug-in system without tools
- Breathable cotton-polyester cover
- Reasonably priced
- High number of variations and equipment possibilities

Size chart

Type	Span width m	Length m	Eave height m	Ridge height m	Area m ²	Number of beds
P10	4.75	5.00	1.70	2.50	23.75	4-6
P11	5.90	4.00	1.90	2.90	23.60	6
P12	5.65	6.00	1.70	2.70	33.90	10
P13	5.90	6.00	1.90	2.90	35.40	10
P16	5.65	8.00	1.70	2.70	45.20	12
P17	5.90	8.00	1.90	2.90	47.20	12
P20	5.65	10.00	1.70	2.70	56.00	16
P21	5.90	10.00	1.90	2.90	59.00	16
P22	5.90	12.00	1.90	2.90	70.80	20

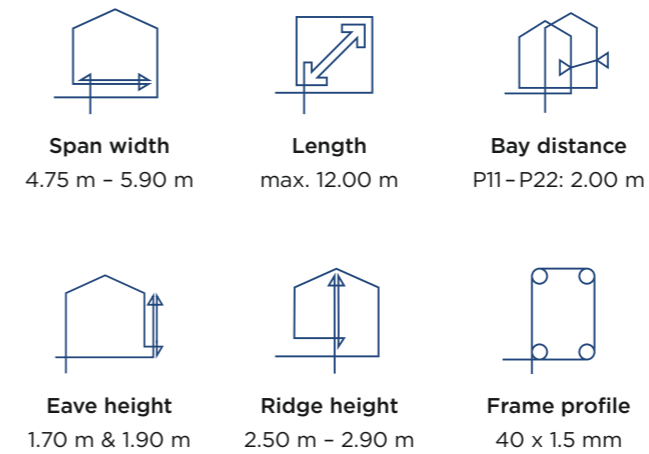

Roof and side covers

Variant 01	Cotton/polyester
Variant 02	Roof: PVC Side walls: Cotton/polyester
Variant 03	PVC

Transport volume

Minimum	P10, in cotton/polyester: 2.60 x 0.80 x 0.75 m, approx. 77 kg
Maximum	P22, in cotton/polyester: 2.60 x 0.80 x 1.00 m, approx. 172 kg Longest component: 2.44 m



Inflatable tents ABZ-H

“ABZ” inflatable tents are extremely quick and easy to set up. Depending on the size and configuration, this generally takes 1 or 2 people around 5 minutes. Inflatable shelters are extremely versatile. They are perfect for providing quick accommodation and medical care.

The tent size comes in a 5.65 m width, variable length up to 13.20 m and 2.27 m wall height. The design allows for multiple uses, with an extensive range of accessories. Thanks to their low transport volume, a standard inflatable shelter can be packed and transported on 1 pallet.

Specifications

- Low transport volume and weight
- Quick assembly and disassembly by means of electrical air pump or compressed air cylinder in a few minutes
- Ideally suited for short-term use
- Various purposes, whether as accommodation, operations center, etc.
- Can be connected with the same tent system

Size chart

Type	Span width m	Length m	Eave height m	Ridge height m	Bay distance m
ABZ Ultimate 1	5.65	5.28	2.27	3.00	2.64
ABZ Ultimate 2	5.65	7.92	2.27	3.00	2.64
ABZ Ultimate 3	5.65	10.56	2.27	3.00	2.64
ABZ Ultimate 4	5.65	13.20	2.27	3.00	2.64



Span width
5.65 m



Length
max. 13.20 m



Bay distance
2.64 m



Eave height
2.27 m



Ridge height
3.00 m

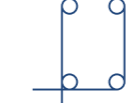

Frame profile
Air beams



Number of beds

ABZ 1	4 beds
ABZ 2	6 beds
ABZ 3	8 beds
ABZ 4	10 beds

Transport volume

ABZ 1	176 kg
ABZ 2	225 kg
ABZ 3	275 kg
ABZ 4	327 kg



Troop tents TRZ-H

Do you need a flexible structure that meets the highest demands? Our accommodation shelters have been developed using high-quality aluminium frames and are multi-functional. They can be used as accommodation, head-quarters, canteens, assembly halls or medical tents with the possibility to connect to other tents or containers. You can configure your tent system to your specification.

It can be adapted to suit a wide range of conditions, no matter how challenging they may be. The tent system can be packaged and transported in a 20 foot container. Depending on the size and configuration it can be set up by 4 people within approximately 20 minutes.

Specifications

- Robust tent system made of aluminum hollow profiles for long-term use
- With high wind and snow for special regions available
- High number of variations and equipment possibilities, such as insulation covers, various flooring systems, etc.
- Various purposes, whether as accommodation, operations center, etc.

Size chart

Eave height	Span width						
	3.00 m	4.00 m	6.00 m	8.00 m	9.00 m	10.00 m	
2.30 m	Ridge height	2.84 m	3.01 m	3.38 m	3.74 m	3.93 m	4.11 m

Note: All measurements are standard dimensions. Custom-made solutions can be offered, subject to static calculations. Higher wind and snow loads are available upon request, dependent on regional requirements.

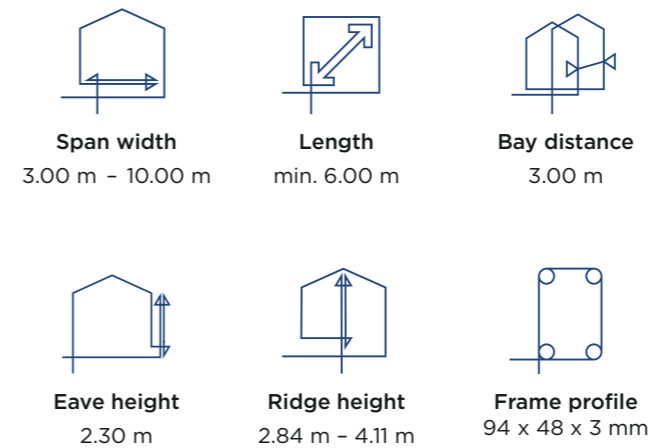

Roof and side covers

Variant 01	Soft PVC covers (non-insulated)
Variant 02	Soft PVC covers including soft-insulation covers and optional sun shade protection cover for hot temperatures (medium insulated)
Variant 03	Insulated hard walling system, made out of sandwich panels and soft PVC covers and sun shade protection cover for hot temperatures (well insulated)

Transport volume

Standard size	3.10 m x 1.00 m x 1.50 m, approx.: 685 kg
6.00 m x 9.00 m	Longest component: 2.75 m



Large tents GZ-H

“GZ” large tents provide large ideas suitable for canteens, conference rooms as well as waiting and relaxation areas. Wall, roof and floor options are available at various prices and with varying degrees of comfort. Large tents are equipped with an extruded aluminum frame that can withstand high snow and wind without any problem. The tent systems

are built according to recognised standard specifications and can be adapted to country-specific requirements. They are available in different sizes and unlimited lengths. These large tents can be packed and transported in 20-foot containers and, depending on their size and configuration, can be set up in just a few hours.

Specifications

- Span width from 10.00 m to 50.00 m
- High number of variations and equipment options, such as insulation covers, various flooring systems, hard roofing and walling, etc.

Size chart

Eave height		Span width							
		10.00 m	12.00 m	15.00 m	20.00 m	25.00 m	30.00 m	40.00 m	50.00 m
2.40 m	Ridge height	4.22 m	4.36 m	4.80 m	5.65 m	6.40 m			
3.00 m	Ridge height	4.82 m	4.96 m	5.40 m	6.25 m	7.00 m	7.87 m		
4.00 m	Ridge height			6.40 m	7.25 m	8.00 m	8.87 m	10.35 m	12.00 m

Note: All measurements are standard dimensions. Custom-made solutions can be offered, subject to static calculations. Higher wind and snow loads are available upon request, dependent on regional requirements.

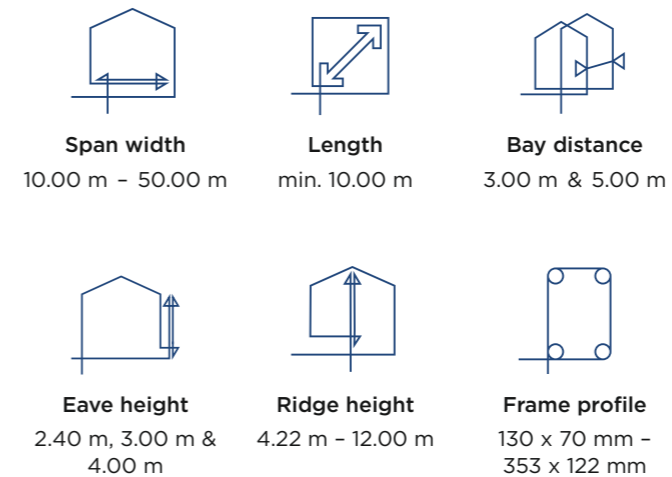

Roof and side covers

Variant 01	Soft PVC covers (non-insulated)
Variant 02	Soft PVC covers including soft-insulation covers and optional sun shade protection cover for hot temperatures (medium insulated)
Variant 03	Insulated hard walling system, made out of sandwich panels and soft PVC covers and sun shade protection cover for hot temperatures (well insulated)
Variant 04	Insulated hard walling system, made out of sandwich panels and thermo-roof covers (well insulated)
Variant 05	Insulated hard walling and roofing system, made out of sandwich panels (extrem well insulated, permanent use)

Transport volume

Example Variant 01 Approx. 1.000 m² tent area on a HGV or 40 ft. container
Weight: approx. 12 kg/m²

Accessories overview

Different requirements need different solutions. Our wide range of accessories provides almost unlimited possibilities. You can customize your tent to your specific needs – for example, with connecting corridors, extra strong insulation or partitions to divide the space. Find out more details about the features such as weight, colour selection and material of our accessories in the section below.

Insulation

- PVC cover (non-insulated)
- Soft insulation cover (medium insulated)
- Sun shade cover (medium insulated)
- Thermo roof cover (well insulated)
- Sandwich panels (very well insulated)

Room arrangement

- PVC cover
- Sandwich panels

General accessories

- Window
- Door
- Various types of flooring systems
- Lighting
- Heating
- Air conditioning
- Lightning protection

Colour options

PVC:



Cotton/polyester:



Sandwich panels:



All the listed shades are similar to the standard RAL colours. Other colour shades are possible upon request.

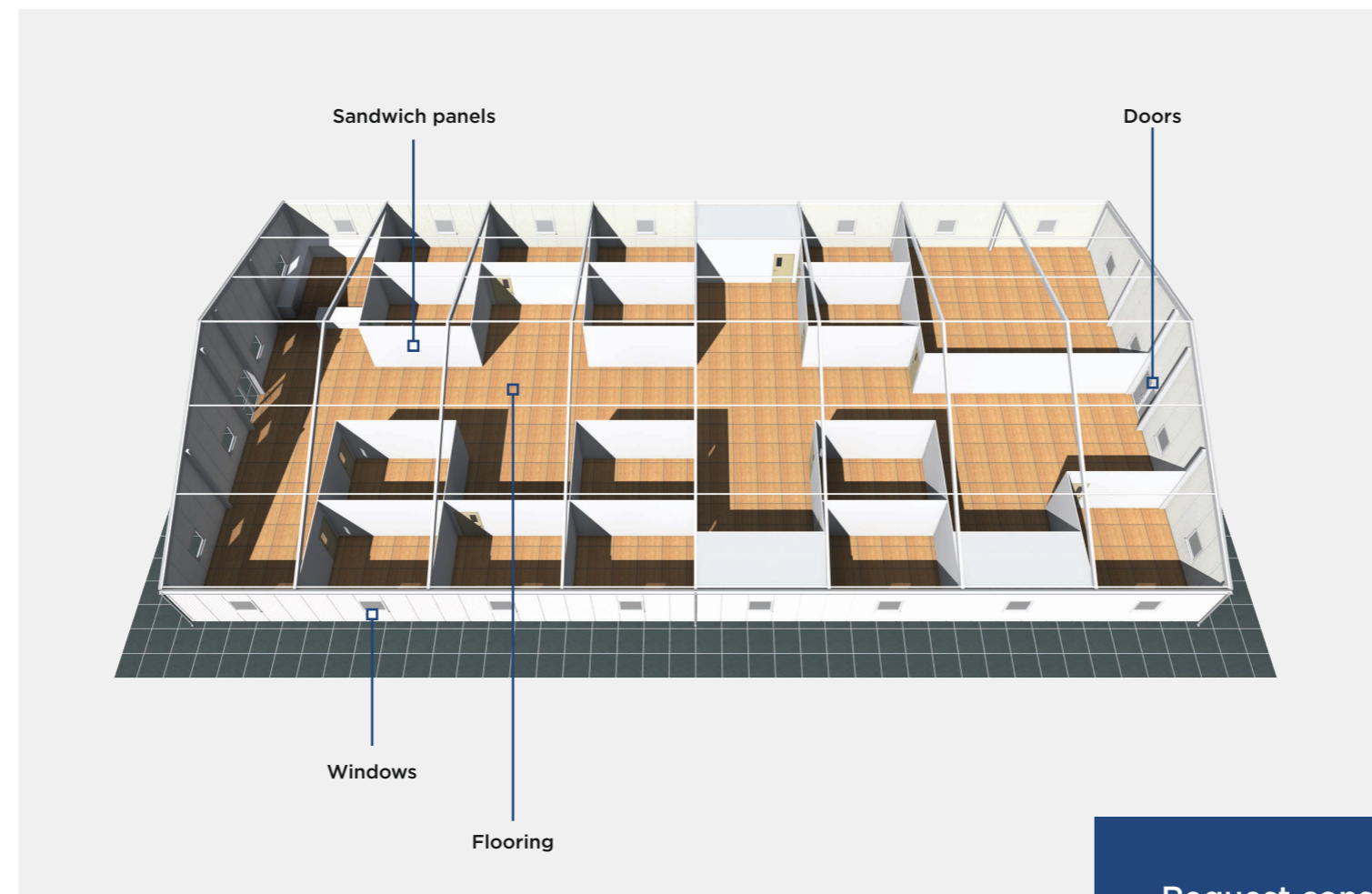

Custom design

Are there any specific requirements that the tent should meet and how it should look? Whether it's the colour of the covers, additional windows, side entrances, rollable sides or custom printing – we can design our tents to suit your needs.

We offer you further equipment features for roofing, facades, insulation, flooring, colour options, printing, etc.

Request consultation

At HTS TENTIQ we've got the right solution to suit your specific requirements. Additional accessories such as HVAC are available on request. Arrange to speak to one of our in-house experts or visit our website at www.hts-tentiq.com.



HTS TENTIQ GmbH
Hinter der Schlagmühle 1
63699 Kefenrod

T +49 60 49 - 95 10 0
verkauf@hts-tentiq.com
www.hts-tentiq.com

